

Apr.1.2017 Copyright 2017 HIROSE ELECTRIC CO., LTD. All Rights Reserved.

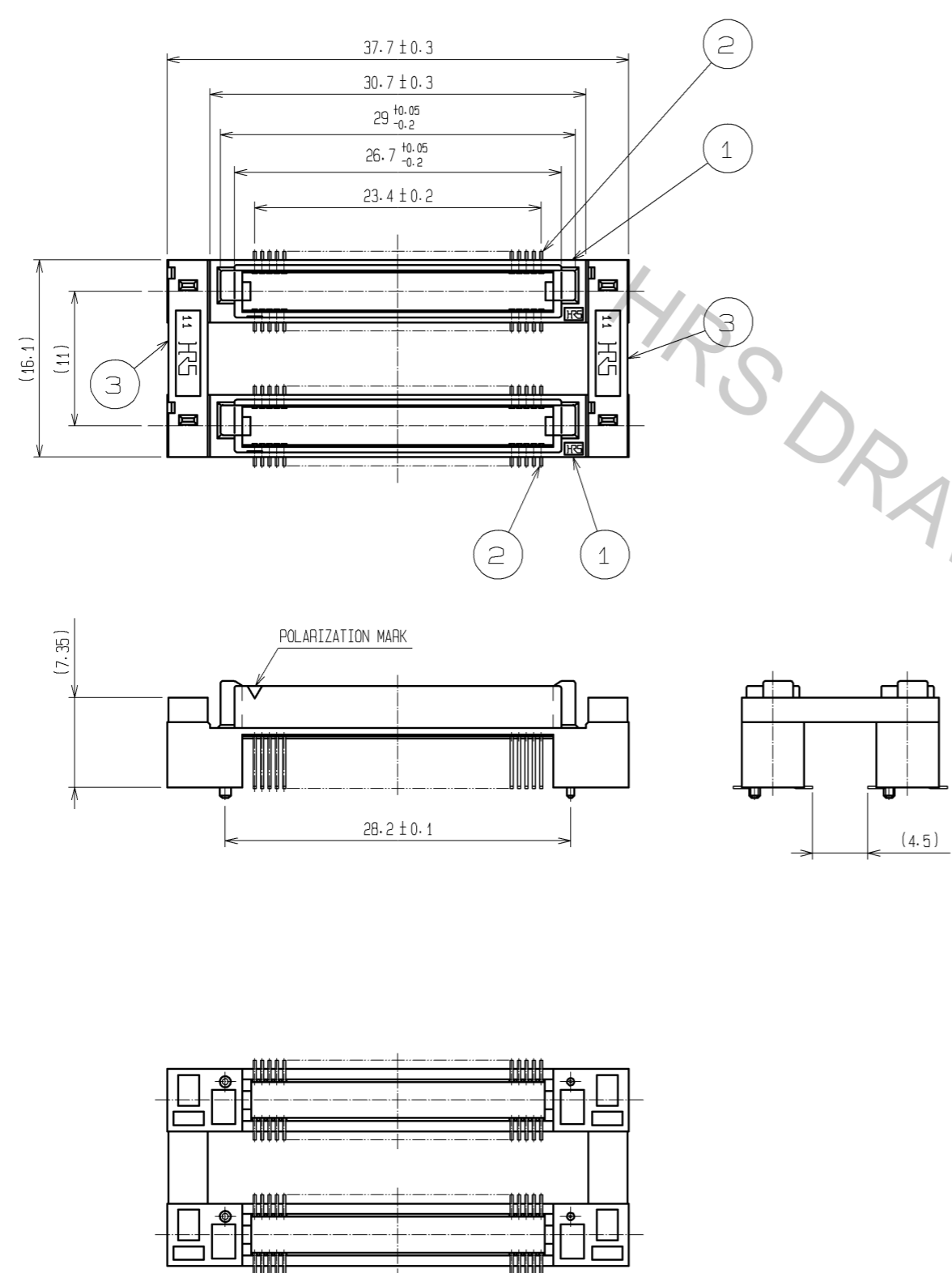

RECOMMENDED LAND PATTERN DIMENSION  
OF PCB(MOUNTING SIDE)  
(RECOMMENDED METAL MASK THICKNESS:0.15mm)

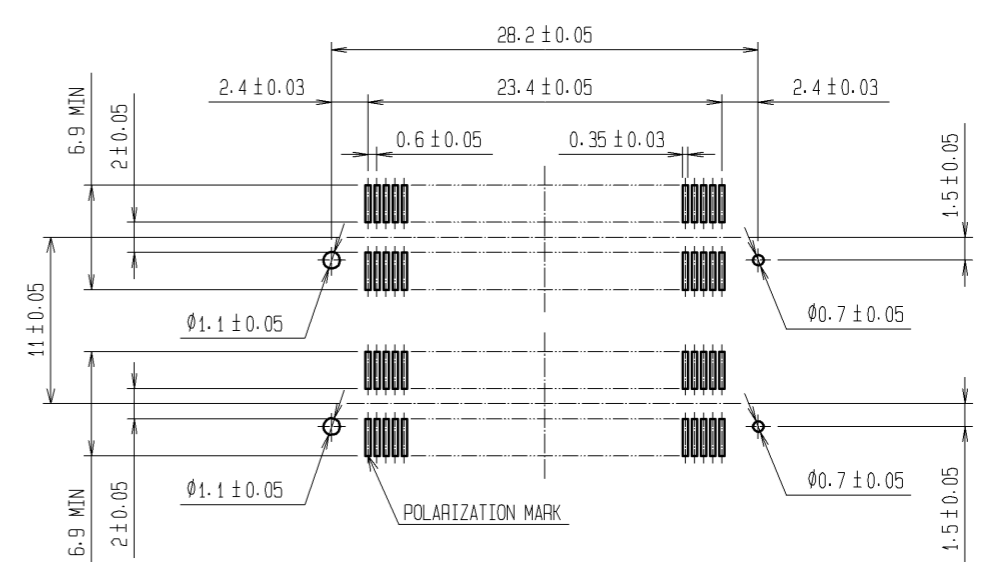

- NOTES
- 1 LEAD CO-PLANARITY SHALL BE 0.1mm MAX.
  - 2 AFTER MOUNTING BOARD, REF. NO. 3 SHALL BE REMOVED.
  - 3 FOR MODIFICATION, ETC., PREVENTIVE HOLE FOR SINK MARK MAY BE ADDED DEPENDS ON CIRCUMSTANCES.
  - 4 THE DIMENSIONS IN PARENTHESES ARE FOR REFERENCE.

1.3	PPS	LIGHT BROWN (UL94V-0)	2	PHOSPHOR BRONZE	CONTACT AREA : GOLD 0.1µm min. LEAD AREA:TIN-PLATING 1µm min. UNDER PLATING:NICKEL 1µm min.		
NO.	MATERIAL	FINISH . REMARKS	NO.	MATERIAL	FINISH . REMARKS		
UNITS mm		SCALE 2 : 1	COUNT 	DESCRIPTION OF REVISIONS	DESIGNED	CHECKED	DATE
<b>HRS</b> HIROSE ELECTRIC CO., LTD.		APPROVED : HS. OKAWA	11.03.10	DRAWING NO. EDC3-150942-25			
		CHECKED : HT. YAMAGUCHI	11.03.10	PART NO. FX8C-80/80P11-SV4J(71)			
		DESIGNED : AH. EDASHIGE	11.03.07	CODE NO. CL578-0733-4-71			
		DRAWN : AH. EDASHIGE	11.03.07			1/2	

DETAIL AFTER REMOVING JOINT

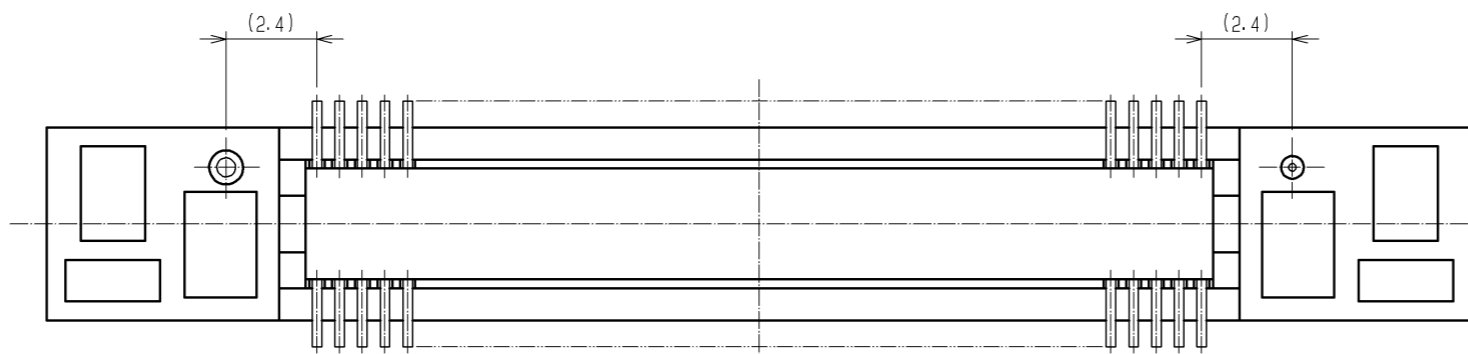
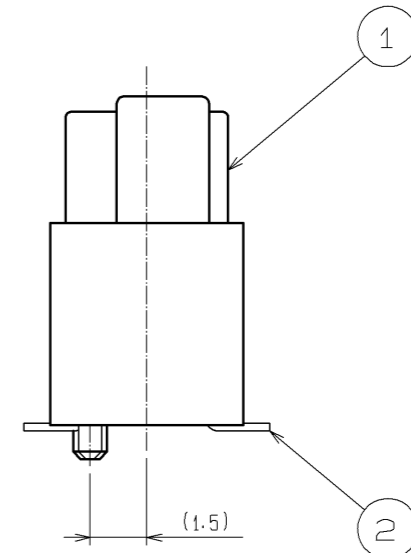
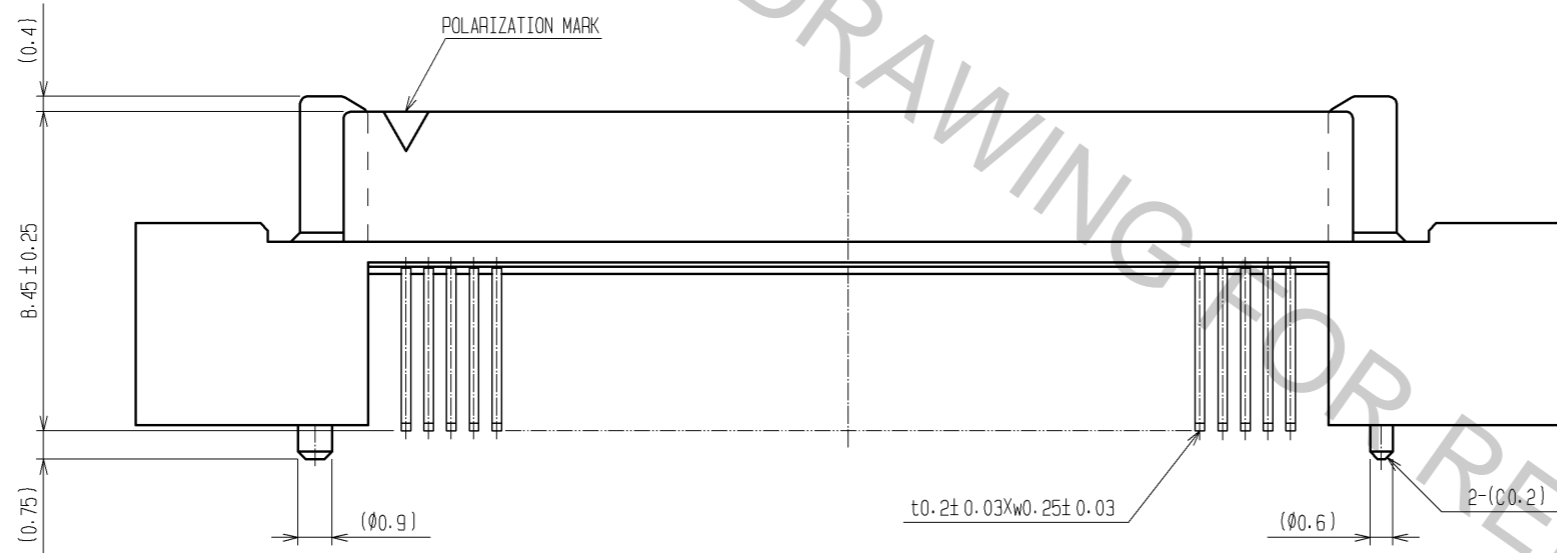
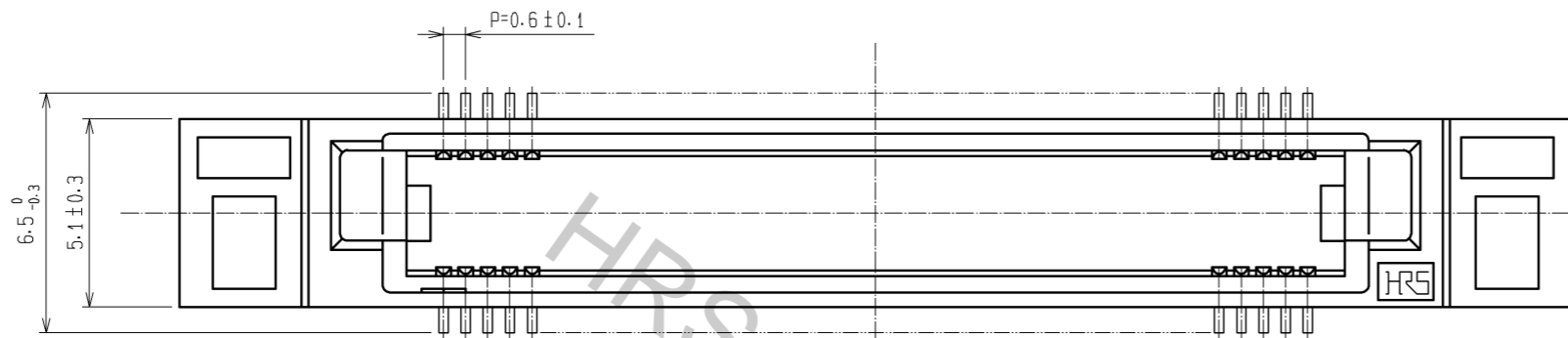

NOTES THE DIMENSIONS IN PARENTHESES ARE FOR REFERENCE.

<b>HRS</b>	DRAWING NO.	EDC3-150942-25
	PART NO.	FX8C-80/80P11-SV4J(71)
	CODE NO.	CL578-0733-4-71
		$\triangle$ 2/2